



A division of **ROSCO**  
[www.gamonline.com](http://www.gamonline.com)

# TwinSpin™

THE DUAL PATTERN ROTATOR

GAM Product #TS5574  
Rosco Product # 205 6670 50120

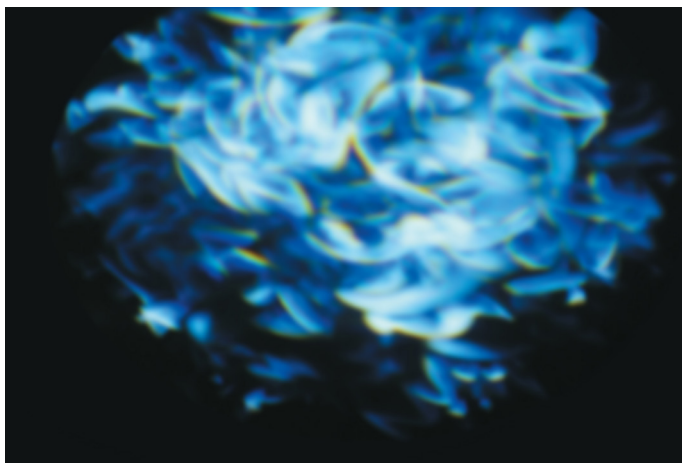

Water/Smoke Effect with #267 Fire  
and GamColor® #810 Moon Blue

## PRODUCT DESCRIPTION

TwinSpin™

A variable speed double-pattern rotator using silent drive belts to rotate two patterns in opposite directions. Designed for use in ellipsoidal spotlights for projected effects, using B size patterns.

Low voltage motor is mounted on vibration pads which minimize noise transmission with 20 gauge stainless steel plates. Motor is offset away from the hot air flow, and drives two special high temperature belts to quietly rotate two gobo rings in opposite directions. Gobo rings have a groove to receive drive belts around the edges and a machined recessed groove to hold gobo pattern and spring steel retaining ring in place. Teflon glides are placed between gobo rings and between gobo rings and outer housing to ensure quiet, smooth operation.

The variable speed motor can be controlled by almost any dimmer and needs no special cables or controller. Motor is powered by UL approved power transformer. The unit may be programmed from a standard light board and controlled as a part of a light cue. Power requirement: 120VAC or optional 230VAC. Select either slow speed motor 0.3 to 3.0 rpm, or high speed motor 0.9 to 9.0 rpm.



## PRODUCT SPECIFICATIONS

Dimensions:

Width: 5.75 in (14 cm)  
Height: 10.875 in (27.6 cm)  
Depth: 3.625 in (9.2 cm)  
Weight : 1.5 lbs (.67 kgs)  
Housing: Stainless Steel  
Power: 120v AC or 230v AC

Connector: 12v DC Motor, deraws 300mA  
2-prong Edison for 120v or 2-prong for 230v  
in European

Cable: 6 ft. #18 WG  
Ring Speed: Slow Speed: 0.3 to 3.0 rpm  
Fast Speed: 0.9 to 9.0 rpm

Pattern: B size

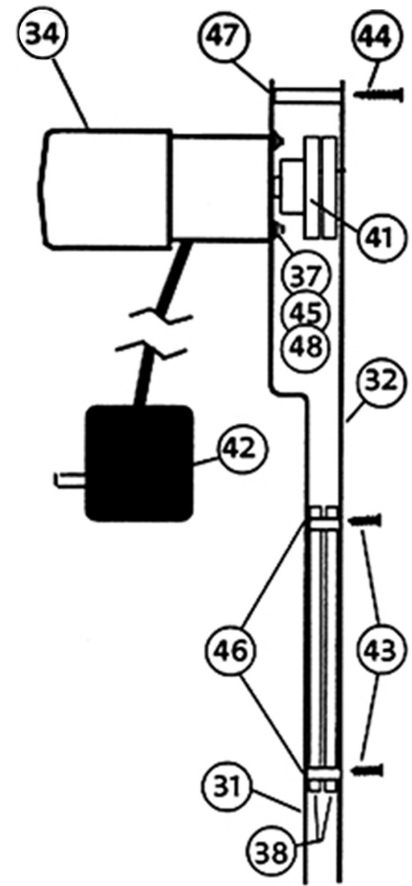
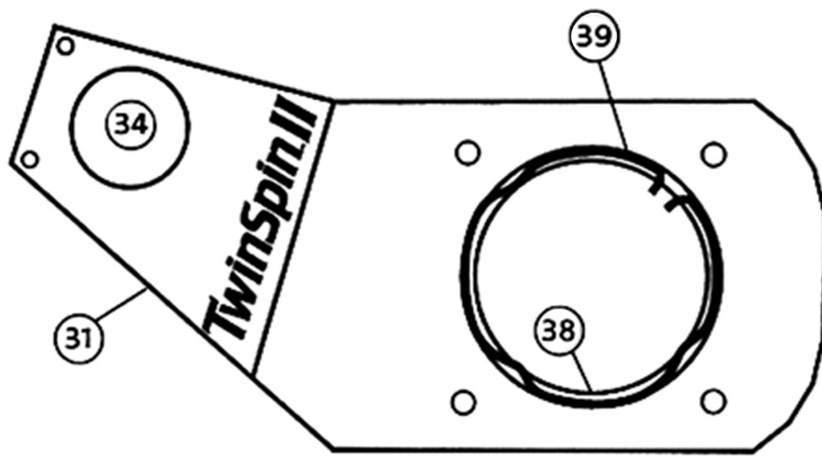

## PRODUCT NUMBER

31	ZPTS2-01 / 206TS2010000	Motor Side Plate
32	ZPTS2-02 / 206TS2020000	Flat Side Plate
34	ZPTS2-05 / 206TS2050000	Motor Cover Cap
35	ZPTS2-06 / 206TS2060000	Teflon Guide Wheel
36	ZPTS2-07 / 206TS2070000	Teflon Washers
37	ZPTS2-08 / 206TS2080000	Motor Grommets
41	ZPTS2-09 / 206TS2090000	Motor Pulley
44	ZPTS2-10 / 206TS2100000	M3 x 16mm C/S Screw Zinc plate
45	ZPTS2-11 / 206TS2110000	M4 Zinc Washer (Motor)
43	ZPTS2-12 / 206TS2120000	M3 x 8mm C/S Screw
48	ZPTS2-13 / 206TS2130000	4-40 x 3/8 Phl Flat Screw
40	ZPTS2-15 / 206TS2150000	Long Drive Belt
40	ZPTS2-16 / 206TS2160000	Short Drive Belt
38	ZPTS2-17 / 206TS2170000	Gobo Ring
39	ZPTS2-18 / 206TS2180000	Retaining Spring
42a	ZPTS2-40 / 206TS2400000	6-Step Transformer 120V
42b	ZPTS2-20 / 206TS2200000	230 V Transf'Rnd ended cncetor
46	ZPTS2-21 / 206TS2210000	M3 x 12mm Spacer
47	ZPTS2-22 / 206TS2220000	M3 x 22mm Spacer
	ZPTS2-24 / 206TS2240000	230V Speed Ctrl W/Trnsfmr
	ZPTS2-25 / 206TS2250000	Black Tie Wrap 5.58" x .142
	ZPTS2-40 / 206TS2400000	6-Step Transformer 120V
	ZPTS2-40A / 206TS240A000	6-Step Transformer 120V
	ZPTS2-41 / 206TS2410000	6-Step Transformer w/Spd Cntrl
	ZPTS2-42 / 206TS2420000	220-Volt 6-Step Transformer

## Motor

ZPTS2-582.1 / 206TS2582100	refer to ZPTS2-582.1
ZPTS2-297.1 / 206TS2297100	Motor' Ratio 297:1
ZPTS2-96.1 / 206TS2961000	Fast Motor' Ratio 96:1

